

Cuisinart® Countertop Cooking

INSTRUCTION BOOKLET



Programmable Slow Cooker

PSC-400

For your safety and continued enjoyment of this product, always read the instruction book carefully before using.

IMPORTANT SAFEGUARDS

When using an electrical appliance, basic safety precautions should always be followed:

1. READ ALL INSTRUCTIONS.

2. Do not touch hot surfaces; use handles or knobs.
3. To protect against risk of electrical shock, do not immerse the slow cooker housing in water or any other liquid. If housing falls into liquid, unplug the cord from outlet immediately. DO NOT reach into the liquid.
4. To avoid possible accidental injury, close supervision is necessary when any appliance is used by or near children.
5. Unplug from outlet when not in use and before cleaning. Allow to cool before putting on or taking off parts.
6. Do not operate any appliance with a damaged cord or plug or after the appliance has malfunctioned or has been dropped or damaged in any way or is not operating properly. Return the appliance to the nearest Customer Service (see Warranty for details) for examination, repair or mechanical or electrical adjustment.
7. The use of attachments not recommended by Cuisinart may cause fire, electrical shock, or risk of injury.
8. Do not use outdoors or anywhere the cord or unit housing might come into contact with water while in use.

9. Do not use the slow cooker for anything other than its intended use.
10. To avoid the possibility of the slow cooker being accidentally pulled off work area, which could result in damage to the slow cooker or personal injury, do not let cord hang over edge of table or counter.
11. To avoid damage to cord and possible fire or electrocution hazard, do not let cord contact hot surfaces, including a stove.
12. Extreme caution must be used when moving a slow cooker containing hot oil or other hot liquids.
13. Do not place on or near a hot gas or electric burner, or in a heated oven.
14. Do not operate slow cooker in water or under running water.
15. Avoid sudden temperature changes, such as adding refrigerated foods to a heated pot.
16. **CAUTION: TO REDUCE THE RISK OF ELECTRIC SHOCK, COOK ONLY IN THE CERAMIC POT PROVIDED OR IN CERAMIC CONTAINERS PLACED ON THE COOKING RACK IN THE PROVIDED CERAMIC POT. DO NOT USE METAL CONTAINERS.**
17. **CAUTION:** A heated ceramic pot may damage countertops or tables. When removing the hot ceramic pot from the slow cooker, DO NOT place it directly on any unprotected surface. Always set the hot pot on a trivet or a rack.
18. To disconnect, press the On/Off button, and then remove the plug from the wall outlet.

SAVE THESE INSTRUCTIONS

FOR HOUSEHOLD USE ONLY

SPECIAL CORD SET INSTRUCTIONS

A short power supply cord is provided to reduce the risks of becoming entangled in or tripping over a longer cord. Longer extension cords are available and may be used if care is exercised. If a long extension cord is used, the marked electrical rating of the extension cord should be at least as great as the electrical rating of the appliance. The longer cord should be arranged so that it will not drape over the countertop or tabletop where it can be pulled on by children or tripped over unintentionally.

NOTICE

This appliance has a polarized plug (one prong is wider than the other). As a safety feature, this plug will fit into a polarized outlet only one way. If the plug does not fit fully in the outlet, reverse the plug. If it still does not fit, contact a qualified electrician. Do not attempt to defeat this safety feature.

CONTENTS

Important Safeguards	2
Introduction	3
Features and Benefits	4
Assembly Instructions	4-5
Operation	
Cooking with Timer	5
Setting Cooking Modes	5
Cooking without Timer	7
Cleaning and Maintenance	7
Warranty Information	10

INTRODUCTION

Get ready to enjoy the easiest homemade dinners ever...perfectly cooked, warm and waiting when you walk in the door. Once you plug in your new Cuisinart® Programmable Slow Cooker and read our instructions, you'll see how easy it is to use – and how many different things you can cook! With a slow cooker, all the work is done ahead of time, so dinnertime is as relaxing for the cook as it is for the diners. Enjoy!

FEATURES AND BENEFITS

1. Glass Lid with Stainless Steel Rim and Chrome-Plated Handle

See-through glass lid keeps ingredients moist. Stainless steel complements any kitchen. (Not oven-safe.)

2. Cooking Rack

Allows you to use a 1-quart soufflé pan in your Slow Cooker.

3. Ceramic Pot

4-quart round ceramic pot accommodates larger cuts of meat. Stick resistant and dishwasher safe for easy cleaning.

4. Stainless Steel Housing

Stainless steel construction is easy to clean, while wraparound heating elements ensure even cooking.

5. Cooking Time Display

Large display in blue background shows remaining cook time. Countdown time up to 24:00 hours.

6. Timer Control

24-hour timer allows you to set the cook time. After the time expires, the unit automatically switches to the Warm setting.

7. LOW, HIGH and SIMMER Indicator Lights

Indicates the unit is cooking on the Low, High or Simmer setting.

8. WARM Indicator Light

Indicates the unit has automatically switched to the

Warm setting if time has expired, or the unit has been manually switched to Warm.

9. Chrome-Plated Handles

Cool-touch insulated handles.

10. Retractable Cord Storage (not shown)

Convenient retractable cord storage.

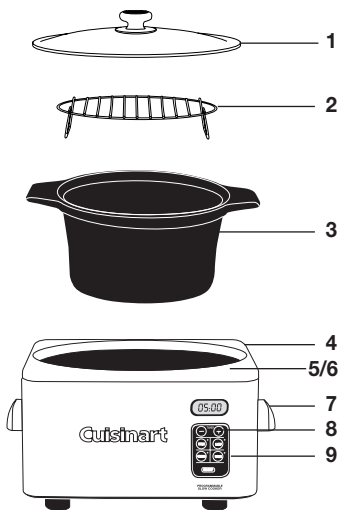

ASSEMBLY INSTRUCTIONS

To use your Cuisinart® Slow Cooker:

1. Carefully unpack the Slow Cooker.
2. Rinse the ceramic pot and glass lid in warm, soapy water. Rinse well and dry thoroughly.
3. Wipe all interior and exterior surfaces of the Slow Cooker base with a soft, damp cloth.

-
- Place ceramic pot in the base of the unit.
 - Place the lid on top of the ceramic pot.
 - Plug in power cord. Your slow cooker is now ready for use.
 - Set the desired cooking time by pushing the + or - button. The timer ranges from 00:00 to 24:00 hours in 30-minute increments.

NOTE: If there is no timer input, the On/Off and the colon on the reading display will continue to flash.

- Press the + button to increase time in 30-minute increments or press the - button to decrease time in 30-minute increments.
- Press and hold + or - to scroll automatically in 30-minute steps.
- Press + and - simultaneously to reset to 00:00. Repeat the above two steps to reset time.
- After setting time, timer display and On/Off indicator will still flash. Please proceed to setting the cooking mode

OPERATION

Your Cuisinart® Slow Cooker cooks food automatically once you set the time and the desired cooking mode. When time expires, the unit automatically switches to the Warm setting and the Warm indicator light illuminates. When cooking time and mode are set, the unit will perform those functions until the cooking time expires or the unit is manually turned off.

Cooking WITH the Timer

- Place the unit on a clean, dry counter.
- Remove glass lid.
- Fill ceramic pot with ingredients.
- Replace lid.
- Plug in unit. There will be no power to the slow cooker until it is turned on.
- To turn unit on, press On/Off button. The slow cooker will beep once, and the On/Off red indicator light and colon (:) on the LCD display will flash.

- Setting Cooking Modes
Three cooking modes, Simmer, Low and High, give you the opportunity to prepare a wider variety of dishes. You can adapt many recipes to slow down the cooking time, or speed it up, to coordinate meals to your schedule.

You will usually want to use the Simmer or Low setting for recipes that cook longer. If you're starting a dish later in the day, select the High setting to ensure that your food is cooked, warm, and ready when you'd like to eat.

Please refer to table below for cooking guidelines.

Setting	Guidelines	Recipes	Program Temp.	Timer
High	This is the setting to use when you don't have time for a long, slow cook. It's also the setting to select when "baking" in your slow cooker.	Potatoes, casseroles, puddings, rolls	212°F (100°C) 165°F (74°C)	Programmable up to 24 hours, then 8 hours (Warm)
Low	Low is the standard slow cooker temperature, and is ideal for foods that you start in the morning before work, and enjoy at the end of your day.	Braises, roasts, stews, ribs, casseroles, shanks, chops, less tender cuts of meat soups	200°F (93°C) 165°F (74°C)	Programmable up to 24 hours, then 8 hours (Warm)
Simmer	The longer the cooking time, the more flavors blend together and intensify. Use this for soups, stews and homemade stocks.	Soups, stews, stocks	185°F (85°C) 165°F (74°C)	Programmable up to 24 hours, then 8 hours (Warm)
Warm	Do not use this setting to cook food or as a cooking function. This setting intended only to use with preheated foods.	----	165°F (74°C)	Defaults or programmable up to 8 hours

- When the desired cooking mode is selected, the unit will beep once, the blue indicator next to Low, High or Simmer will illuminate to denote the selected cooking mode, and any flashing light will become solid.
NOTE: The cooking mode can be overridden by pressing any other mode buttons.
- Once cooking time has expired, the unit will automatically switch to the Warm setting. The blue indicator light next to the Warm setting will light and remain on Warm for 8 hours maximum (this time can be adjusted at any time). When the Warm time expires, the unit will beep for 5 seconds and then turn off automatically.

-
9. To turn the unit off manually, press the On/Off button.
 10. Lift ceramic pot carefully, using potholders.

NOTE: The U.S. Department of Agriculture (USDA) recommends that when cooking anything containing meat in a slow cooker, the meat should reach 140°F within 2 hours. This ensures that the meat will reach food-safe temperatures in the proper amount of time.

Cooking WITHOUT the Timer

If no timer is set in conjunction with any cooking setting, the selected cooking setting of High, Low or Simmer will default to 24-hour cooking time.

1. Place the unit on a clean, dry counter.
2. Remove glass lid.
3. Fill ceramic pot with ingredients.
4. Replace lid.
5. Plug in unit. There will be no power to the slow cooker until it is turned on.
6. To turn unit on, press On/Off button. The slow cooker will beep once, and the On/Off indicator red light and colon (:) on the LCD display will flash.
7. Set the desired cooking modes by pressing High, Low or Simmer setting. Refer to the cooking table guidelines on page TBD. Once 24-hour default cooking time has expired, the unit will automatically switch to the Warm setting for 8 hours.

If you choose to use the timer, please refer to the Cooking With the Timer section and follow Line 7.

8. When the desired cooking mode is selected, the unit will beep once, the blue indicator next to Low, High or Simmer will illuminate to denote the unit is the selected cooking mode, and any flashing will become solid. **NOTE:** The cooking mode can be overridden by pressing any other mode buttons.
9. Once cooking time has expired, the unit will automatically switch to the Warm setting. The blue indicator light next to Warm setting will light and remain on Warm for 8 hours maximum (this time can be adjusted at any time). When the Warm time expires, the unit will beep for 5 seconds and will turn off automatically.
10. To turn the unit off manually, press the On/Off button.
11. Lift ceramic pot carefully, using potholders.

CLEANING AND MAINTENANCE

Unplug your Cuisinart® Slow Cooker and allow it to cool before cleaning. Place ceramic pot and lid in the dishwasher or wash with warm, soapy water. If food sticks to the surface, fill ceramic pot with warm, soapy water and allow to soak before cleaning. If scouring is necessary, use a nonabrasive cleanser or liquid detergent with a nylon pad or brush.

NOTES

WARRANTY

Limited Three-Year Warranty

This warranty supersedes all previous warranties on the Cuisinart® Slow Cooker.

This warranty is available to consumers only. You are a consumer if you own a Cuisinart® Slow Cooker that was purchased at retail for personal, family or household use. Except as otherwise required under applicable state law, this warranty is not available to retailers or other commercial purchasers or owners.

We warrant that your Cuisinart® Slow Cooker will be free of defects in material or workmanship under normal home use for three years from the date of original purchase.

We suggest that you complete and return the enclosed product registration card promptly to facilitate verification of the date of original purchase. However, return of the product registration card is not a condition of these warranties.

If your Slow Cooker should prove to be defective within the warranty period, we will repair it (or, if we think it necessary, replace it) without charge to you. To obtain warranty service, please call our Consumer Service Center toll-free at 800-726-0190 or write to:

Cuisinart
150 Milford Road
East Windsor, NJ 08520

To facilitate the speed and accuracy of your return, please also enclose \$10.00 for shipping and handling of the product (California residents need only supply proof of purchase and should call 1-800-726-0190 for shipping instructions). Please also be sure to include a return address, description of the product defect, product serial number, and any other information pertinent to the product's

return. Please pay by check or money order.

Your Cuisinart® Slow Cooker has been manufactured to strict specifications and has been designed for use with the Cuisinart® slow cooker authorized accessories and replacement parts for your model. These warranties expressly exclude any defects or damages caused by accessories, replacement parts or repair service other than those that have been authorized by Cuisinart.

These warranties exclude all incidental or consequential damages. Some states do not allow the exclusion of or limitation of incidental or consequential damages, so the foregoing limitation or exclusion may not apply to you.

CALIFORNIA RESIDENTS ONLY

California law provides that for In-Warranty Service, California residents have the option of returning a nonconforming product (A) to the store where it was purchased or (B) to another retail store which sells Cuisinart products of the same type. The retail store shall then, according to its preference, either repair the product, refer the consumer to an independent repair facility, replace the product, or refund the purchase price less the amount directly attributable to the consumer's prior usage of the product. If the above two options do not result in the appropriate relief to the consumer, the consumer may then take the product to an independent repair facility if service or repair can be economically accomplished. Cuisinart and not the consumer will be responsible for the reasonable cost of such service, repair, replacement, or refund for nonconforming products under warranty.

California residents may also, according to their preference, return nonconforming products directly to Cuisinart for repair or, if necessary,

replacement by calling our Consumer Service Center toll-free at 800-726-0190. Cuisinart will be responsible for the cost of the repair, replacement, and shipping and handling for such nonconforming products under warranty.

BEFORE RETURNING YOUR CUISINART PRODUCT

Important: If the nonconforming product is to be serviced by someone other than Cuisinart's Authorized Service Center, please remind the servicer to call our Consumer Service Center to ensure that the problem is properly diagnosed, the product serviced with the correct parts, and to ensure that the product is still under warranty.

Cuisinart®

SAVOR THE GOOD LIFE™



Coffeemakers



Food Processors



Toaster Ovens



Blenders



Cookware



Ice Cream Makers

Cuisinart offers an extensive assortment of top quality products to make life in the kitchen easier than ever. Try some of our other countertop appliances and cookware, and Savor the Good Life™.

www.cuisinart.com

©2008 Cuisinart
Cuisinart® is a registered
trademark of Cuisinart

150 Milford Road
East Windsor, NJ 08520
Printed in China

08CU419

U IB-7516A

Version no: PSC400 IB-7516A

SIZE:114mm(W) X178 mm(H)
Total Pages:12pp

Material:
Cover:157gsm matt artpaper
Inside:120gsm gloss artpaper

Coating: Varnishing in cover

Color:
Cover:4C+1C(black)
Inside:1C+1C(black)

Die cut:same as psc400 IB-7516

Bar Code:N.A.

Date:08/18/08(01)

Coordinator: Astor You

 CHUNG TAI PRINTING HOLDINGS LTD.
中大印刷集團有限公司

Tel: 2669 6173 Fax: 2677 6556

C

M

Y

K